

116 Series

Heavy Duty Door Closer



16'-5"

1'-11"

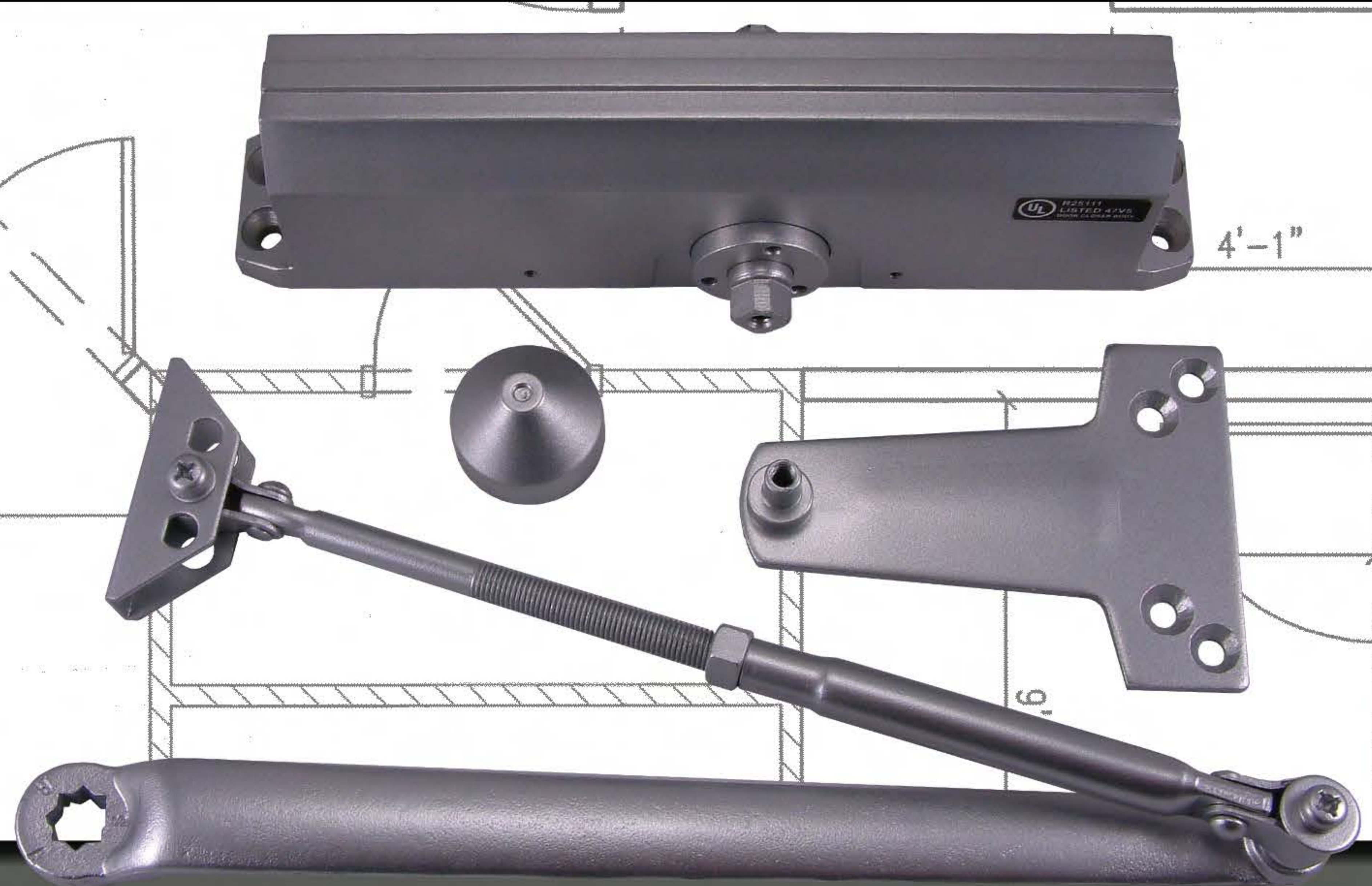

Specifications

ANSI: Meets ANSI A156.4 - Grade 1 Standards

UL Listings: UL Listed for "A" Label 3 Hour Fire Doors, UL10C Positive Pressure Rated

ADA Compliance: Meets ADA requirements ANSI A117.1

Closer Body: Heavy Duty Cast Aluminum Closer Body with Rack & Pinion Const.

Piston, Spindle, Spring: Heat Treated Heavy Duty Steel Piston, Spindle & Spring

Spring Sizing: Adjustable Spring Power from Size 1 to 4 - Factory preset at size 3

Speed Controls: Independent Latch & Sweep Speed Controls

Back Check: Back Check Intensity Control Standard

Valves: Staked Valves to prevent backing valves out too far

Included Parts: Plastic Pinion Cap & PA Bracket included

Covers: Molded Plastic Cover available seperately

CTC Hole Pattern: 9 1/16" CTC Horizontally x 3/4" CTC Vertically

Projection: 2 7/8" projection without cover

Minimun Top Rail: Regular: 3 1/8" - Top Jamb: 1 7/8" - Parallel Arm: 5 3/4"

Fasteners: Machine screws & Thru Bolts, Wood screws & Self tapping machine screws included

Mounting styles: Includes all screws and brackets for Regular, Top Jamb and Parallel Arm Installations

Accessories: Hold Open Arms, Heavy Duty Arms, Drop Plates, Extended Arms & more...

Warranty: Limited Lifetime Warranty



Available Finishes

DH #	US #	BHMA #	Finish Description
AL	ALUM	689	Aluminum Painted
BZ	DURO	690	Dark Bronze Painted

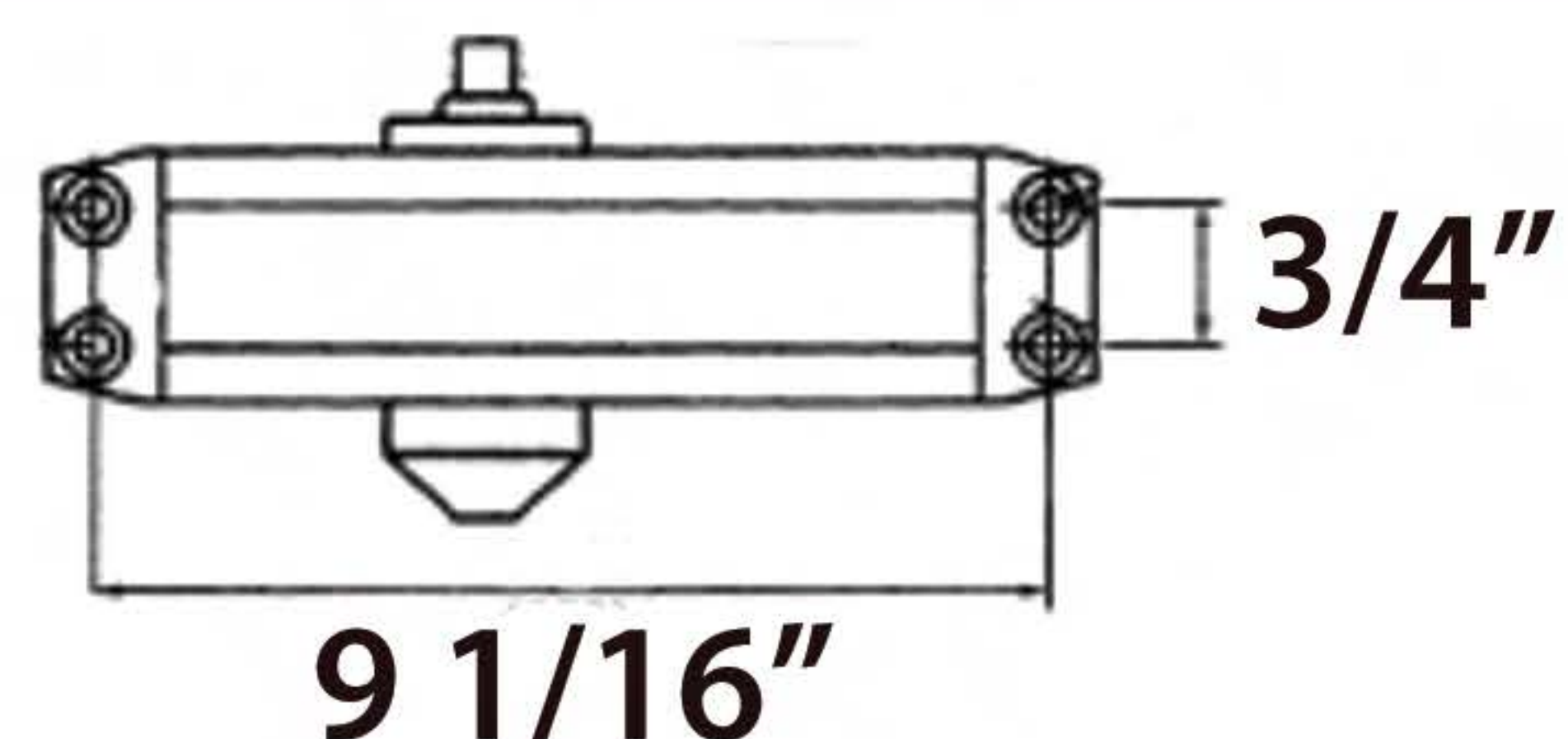

211 Endeavor Drive - PO Box 680
 Rogersville, MO 65742
 PH 877-258-1262 FX 877-888-0150
www.designhardware.net